

# Series and Parallel Circuits

Textbook pages 306–319

## Before You Read

A circuit is a complete pathway like an electric circuit or a school running track. What other examples of circuits can you list?

---



---

### Mark the Text

#### Identify Concepts

As you read, highlight each question head in this section. Then use a different colour to highlight the answers to the questions.

#### Reading Check

1. What is a series circuit?

---



---



---

#### Reading Check

2. What is a parallel circuit?

---



---



---

### What is a series circuit?

A **series circuit** is an electric circuit that has only one pathway for electric current to take. You can think of a series circuit as a set of parts that are connected end to end. The charges pass through each load before they return to a battery or other energy source. All the moving charges travel through each part of the circuit. ✓

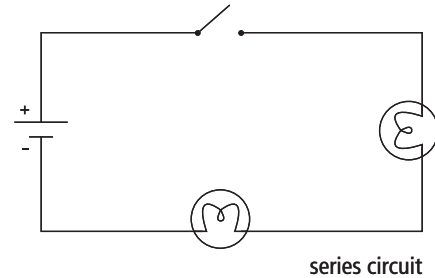

### What is a parallel circuit?

A **parallel circuit** is an electric circuit that has two or more pathways for electric current to take. Some of the moving charges travel through one pathway of the circuit, and other moving charges travel through other pathways of the circuit. All the charges return to the source after moving through the pathways. The place where pathways separate or join in a parallel circuit is called a **junction point**. ✓

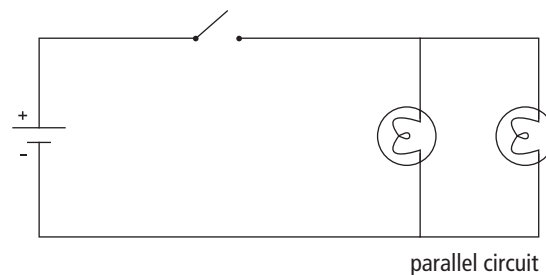

### What happens to the current, voltage, and resistance in series and parallel circuits?

The table below summarizes the effects that series circuits and parallel circuits have on the current, the voltage, and the resistance of the circuits.

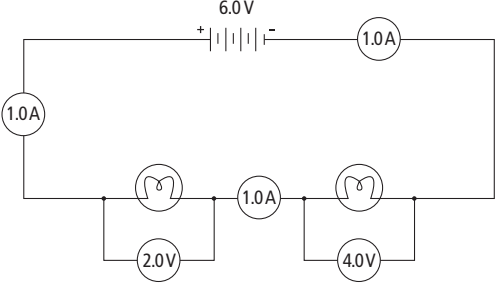
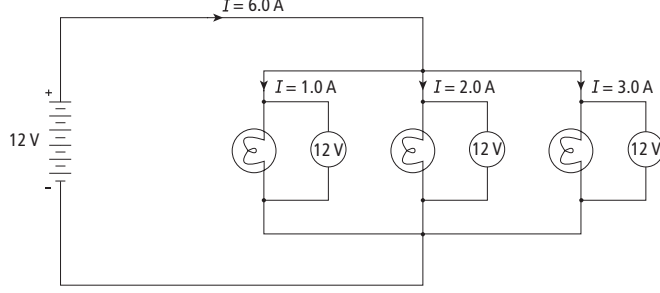
Series circuit	Parallel circuit
	
<p><b>Current</b> The current through the whole circuit is the same throughout and is equal to the total current supplied by the source.</p>	<p><b>Current</b> The current through each pathway of the circuit adds up to the total current supplied by the source.</p>
<p><b>Voltage</b> The voltages across each of the loads in the circuit add up to the voltage supplied by the source.</p>	<p><b>Voltage</b> The voltages across each of the loads in the circuit are equal to each other and to the voltage supplied by the source.</p>
<p><b>Resistance</b> Resistors placed in series increase the total resistance of the circuit. As a result, the total current throughout the circuit decreases.</p>	<p><b>Resistance</b> Resistors placed in parallel decrease the total resistance of the circuit. As a result, the total current through the circuit increases.</p>

Use with textbook pages 306–313.

## Series or parallel?

For each of the following statements, identify whether it applies to a series circuit or a parallel circuit.

1. The current is the same throughout the circuit.

\_\_\_\_\_

2. Adding a resistor will decrease the total resistance of the circuit.

\_\_\_\_\_

3. The voltage across each resistor in the circuit is the same.

\_\_\_\_\_

4. There is only one pathway for electrons to flow.

\_\_\_\_\_

5. Adding a resistor will increase the total resistance of the circuit.

\_\_\_\_\_

6. There is more than one pathway for current to flow.

\_\_\_\_\_

7. As more cells are added to the circuit, the brightness of the light bulb increases.

\_\_\_\_\_

8. There are junction points in the circuit.

\_\_\_\_\_

9. If the current through one load in the circuit goes to 0 A, the current through all other loads remains the same.

\_\_\_\_\_

10. The sum of voltages across the loads equals the total voltage supplied by the battery.

\_\_\_\_\_

11. The total current entering a junction point equals the sum of the current leaving the junction point.

\_\_\_\_\_

Use with textbook pages 306–313.

## Is it in series or in parallel?

Match each description on the left with the correct circuit on the right.

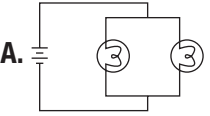
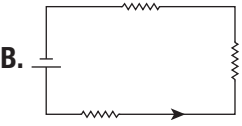
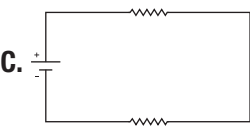
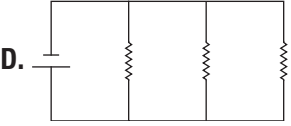
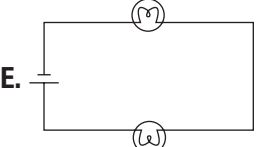
Description	Circuit
1. _____ 3 resistors in series 2. _____ 3 resistors in parallel 3. _____ 2 light bulbs in series 4. _____ 2 light bulbs in parallel	<p><b>A.</b> </p> <p><b>B.</b> </p> <p><b>C.</b> </p> <p><b>D.</b> </p> <p><b>E.</b> </p>

Draw circuit diagrams as directed below.

**5.** Draw a circuit diagram showing one resistor and one light bulb in series.

**6.** Draw a circuit diagram showing one resistor and one light bulb in parallel.

Use with textbook pages 306–313.

## Calculations with series circuits

Use the diagrams to answer the questions below.

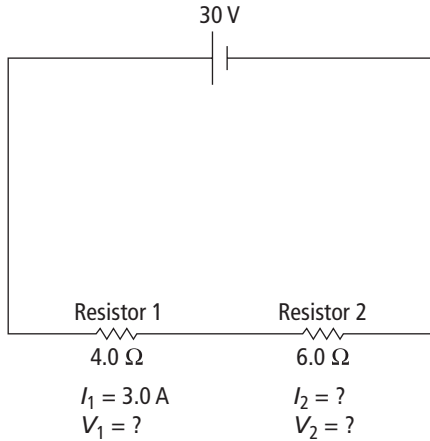

**1. (a)** What is the total resistance in the circuit?

\_\_\_\_\_

**(b)** What is the amount of current flowing through Resistor 2?

\_\_\_\_\_

**(c)** Using Ohm's Law ( $V = IR$ ), determine the voltage drop across Resistor 2.

\_\_\_\_\_  
\_\_\_\_\_  
\_\_\_\_\_

**(d)** What is the voltage drop across Resistor 1? \_\_\_\_\_

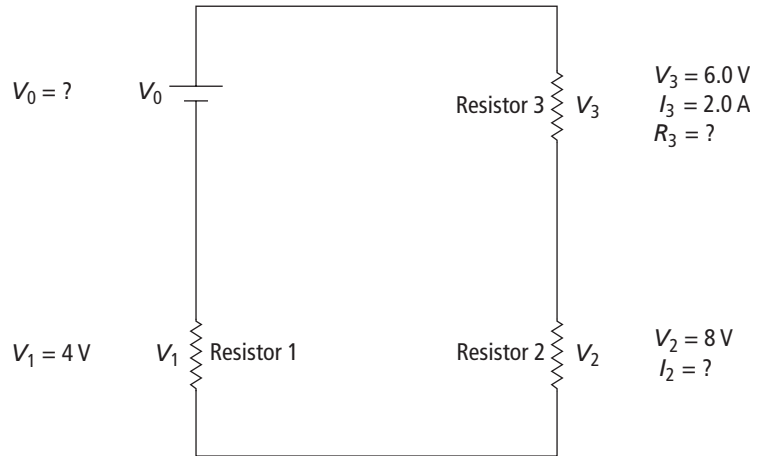

**2. (a)** What is the total voltage in the circuit?

\_\_\_\_\_

**(b)** What is the amount of current flowing through Resistor 2?

\_\_\_\_\_

**(c)** Ohm's law is  $R = \frac{V}{I}$ . Use Ohm's law to determine the resistance of Resistor 3. \_\_\_\_\_

Use with textbook pages 306–313.

## Series and parallel circuits

Match each Description on the left with the Circuit on the right. Each Circuit may be used more than once.

Description	Circuit
1. _____ Resistors decrease the total resistance of the circuit.	<b>A.</b> series circuit <b>B.</b> parallel circuit
2. _____ Resistors increase the total resistance of the circuit.	
3. _____ The voltages across each of the loads in the circuit add up to the voltage supplied by the source.	
4. _____ The voltages across each of the loads in the circuit are equal to each other and to the voltage supplied by the source.	
5. _____ The current through the whole circuit is the same throughout and is equal to the total current supplied by the source.	
6. _____ The current through each pathway of the circuit adds up to the total current supplied by the source.	

Circle the letter of the best answer.

Use the following diagram to answer questions 7 and 8.

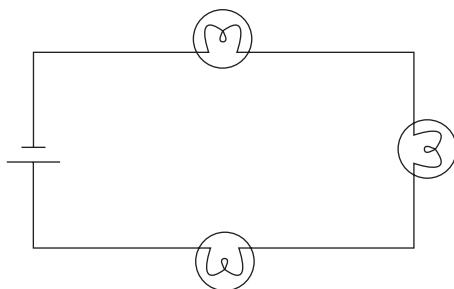

- The light bulbs are connected in parallel.
  - The statement is correct.
  - The statement is incorrect.
  - The diagram does not show whether the statement is correct or incorrect.
- The current is the same throughout the entire circuit.
  - The statement is correct.
  - The statement is incorrect.
  - The diagram does not show whether the statement is correct or incorrect.
- Which of the following statements applies to a series circuit?

I.	There are junction points in the circuit.
II.	There is only one path for electrons to flow.
III.	The total resistance is equal to the sum of the individual resistances.

- I and II only
  - I and III only
  - II and III only
  - I, II, and III
- Which of the following applies to a parallel circuit?
    - There is only one path for electrons to flow.
    - Adding a resistor to the circuit increases the total resistance.
    - The sum of the voltages lost on the resistors equals the total voltage supplied by the battery.
    - The total current entering a junction point must equal the sum of the current leaving the junction point.